



感谢您购买本产品！本产品功率强大，错误的使用可能导致人身伤害和设备损坏，强烈建议您在使用设备前仔细阅读本说明书并保存，严格遵守规定的操作程序。我们不承担因使用本产品或擅自对产品进行改造所引起的任何责任，包括但不限于对附带损失或间接损失的赔偿责任。在保证品质相等前提下，我们有权在不通知的情况下变更产品的设计、外观、性能及使用要求。

## 01 主要特性

- 采用功能强大、高性能MCU处理器；
- 专门针对盘式马达优化的固件，兼容性非常出色；
- 专门针对多旋翼设计的程序，飞行过程中油门调整响应迅速；
- 固件自适应能力强，仅保留四种进角设定项（15°/18.75°/22.5°/26.25°），使用极为简单，同时兼顾稳定性和电池使用寿命；
- 最高可支持刷新率高达500Hz的油门信号，兼容各种飞控（注：>=500Hz的油门信号皆为非标准油门信号）；

## 02 产品规格

| 型号         | 持续电流 | 瞬间电流 [10S] | BEC     | 锂电池节数 | 重量   | 尺寸          |
|------------|------|------------|---------|-------|------|-------------|
| A-FW060006 | 60A  | 80A        | 5.5V/5A | 2-6S  | 88g  | 84x38x19mm  |
| A-FW080006 | 80A  | 100A       | 5.5V/5A | 2-6S  | 88g  | 84x38x19mm  |
| A-FW100006 | 100A | 120A       | 5.5V/5A | 2-6S  | 93g  | 84x38x19mm  |
| A-FW120006 | 120A | 140A       | 5.5V/5A | 2-6S  | 94g  | 84x38x19mm  |
| A-FW060012 | 60A  | 80A        | No      | 5-12S | 88g  | 84x38x19mm  |
| A-FW080012 | 80A  | 100A       | No      | 5-12S | 88g  | 84x38x19mm  |
| A-FW100012 | 100A | 120A       | No      | 5-12S | 93g  | 84x38x19mm  |
| A-FW120012 | 120A | 140A       | No      | 5-12S | 94g  | 84x38x19mm  |
| A-FW150012 | 150A | 170A       | No      | 5-12S | 213g | 133x49x27mm |

\*请联系我们以获得更多产品信息。

## 03 连线示意图

(为避免短路和漏电，请保证连接处绝缘良好)

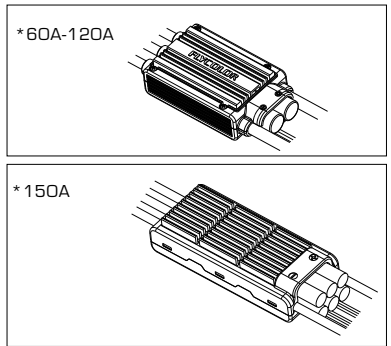
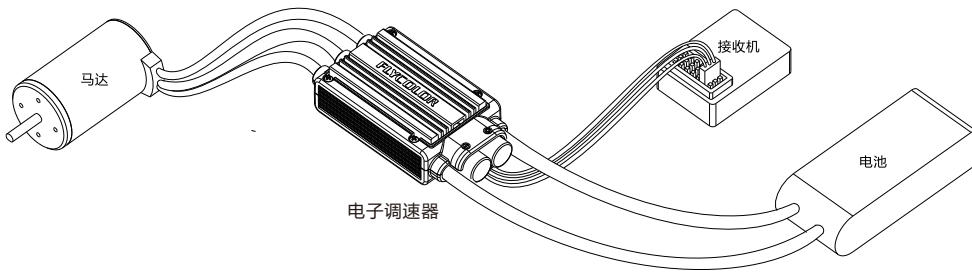

## 04 操作说明

### 1 正常工作模式

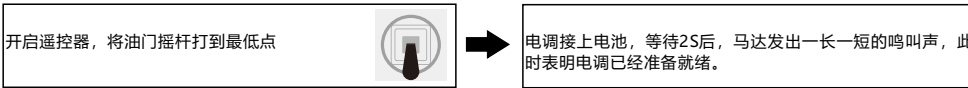

### 2 油门行程设定

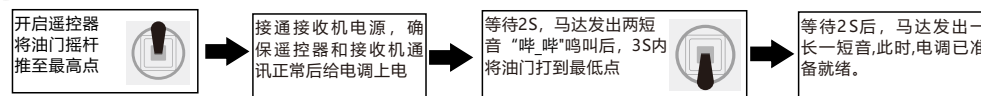

首次使用无刷电调或更换遥控设备后需要进行油门行程校准。

### 3 进角参数设定

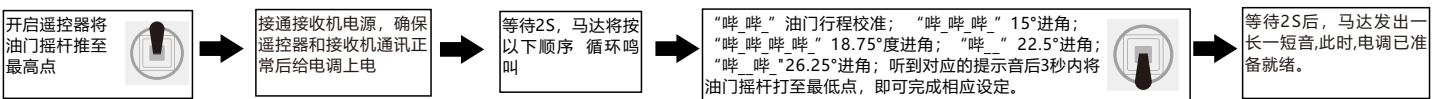

(声音次数>=5次后用一长鸣音“哔\_”表示5)

当电调驱动盘式马达油门急加速时马达出现失步现象堵转或者要求达到更高转速时，可尝试更改进角参数（注：6S电调出厂默认为15°进角，12S为22.5°进角）。更高的进角可提高马达转速，但发热通常也会更多。进行进角调整后，请先于地面进行测试，测试正常后方可起飞。

## 05 保护功能说明

|          |   |
|----------|---|
| 启动保护     | 当加大油门时，三秒内未能正常启动马达，电调将会关闭动力输出，油门摇杆需再次置于最低点后方可重新启动马达（出现这种情况的原因可能有：电调和马达连接线接触不良或有断开、螺旋桨被其他物体阻挡等）。 |
| 过负荷保护    | 当负载突然变得极大时，电调会切断动力，须油门归零后方可正常操作。当马达和电调失步时，电调会自动尝试重新启动。  |
| 油门信号丢失保护 | 当电调检测到油门遥控信号丢失0.32秒以上后立即关闭输出，以免因螺旋桨继续高速转动而造成更大的损失。信号恢复后，电调也随即恢复相应的功率输出。                         |

## 06 常见故障及提示音

| 故障现象      | 警报音                     | 可能原因           | 解决办法                           |
|-----------|-------------------------|----------------|--------------------------------|
| 上电后马达无法启动 | “哔哔哔”的急促短音              | 油门未归零或行程设置过小   | 将油门打至最低点或重新设定油门行程              |
| 上电后马达无法启动 | “哔、哔、哔、.....”（每个间隔1秒）   | 接收机油门通道无油门信号输出 | 检查发射机与接收机配合是否正常；检查油门控制通道接线是否正常 |
| 上电后马达无法启动 | “哔-哔、哔-哔-.....哔-哔-”循环鸣叫 | 油门通道“正反向”错误    | 参考遥控器说明书，调整油门通道正反向设置           |



Thank you for purchasing our brushless electronic speed controller (ESC). Any Improper operation may cause personal injury damage to the product and related equipments. This high power system for RC model can be dangerous, we strongly recommend reading the user manual carefully and completely. We will not assume any responsibility for any losses caused by unauthorized modifications to our product. We have the right to change the design, appearance, performance and usage requirements of the product without notice.

### 01 Main features

- High performance MCU.
- Optimized firmware is specialized for disc motor,excellent compatibility.
- The firmware is specialized for multi-rotor, fast throttle response during flying.
- Strong self-adaptable firmware, 4 timing options.
- Support frequency of throttle signal to 500Hz max, compatible with various kinds of flight control. (≥500Hz throttle signal is nonstandard signal)

### 02 Specifications

| Manufacture Model | Con. Current | Burst Current (10S) | BEC     | LiPo cells | Weight | Size        |
|-------------------|--------------|---------------------|---------|------------|--------|-------------|
| A-FW060006        | 60A          | 80A                 | 5.5V/5A | 2-6S       | 88g    | 84x38x19mm  |
| A-FW080006        | 80A          | 100A                | 5.5V/5A | 2-6S       | 88g    | 84x38x19mm  |
| A-FW100006        | 100A         | 120A                | 5.5V/5A | 2-6S       | 93g    | 84x38x19mm  |
| A-FW120006        | 120A         | 140A                | 5.5V/5A | 2-6S       | 94g    | 84x38x19mm  |
| A-FW060012        | 60A          | 80A                 | No      | 5-12S      | 88g    | 84x38x19mm  |
| A-FW080012        | 80A          | 100A                | No      | 5-12S      | 88g    | 84x38x19mm  |
| A-FW100012        | 100A         | 120A                | No      | 5-12S      | 93g    | 84x38x19mm  |
| A-FW120012        | 120A         | 140A                | No      | 5-12S      | 94g    | 84x38x19mm  |
| A-FW150012        | 150A         | 170A                | No      | 5-12S      | 213g   | 133x49x27mm |

\*Please connect us for more molds and details.

### 03 Wiring diagram

\*Please ensure all solder joints are insulated with heat shrink where necessary.

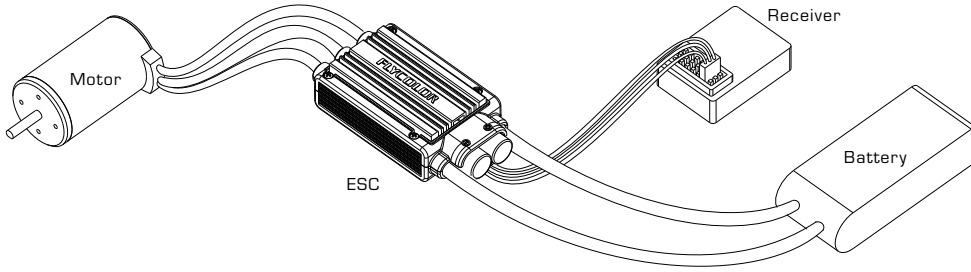

\*60A-120A

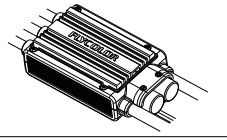

\*150A

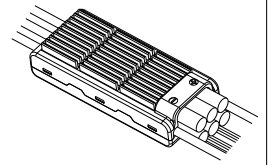

### 04 Operation instruction

#### 1 Normal start-up Process

Turn on the transmitter, move the throttle stick to the bottom position.



Connect ESC & battery packs, wait for 2 seconds, motor emits continuously 1 long and 1 short tone. It means the ESC is ready for working.

#### 2 Set Throttle Range

Turn on the transmitter, move the throttle stick to the top position.



Connect the receiver to the battery, ensure the communication is normal between the transmitter and receiver, then power on the ESC.

Wait for 2 second, after motor emits 2 short "BEEP-BEEP", move the throttle stick to the bottom position in 3 seconds.



Wait for 2 seconds, motor emits continuously 1 long and 1 short tone. It means the ESC is ready for working.



Please set throttle range, when first time to use ESC or change transmitter.

#### 3 Set Timing

Turn on the transmitter, move the throttle stick to the top position.



Connect the receiver to the battery, ensure the communication is normal between the transmitter and receiver, then power on the ESC.

The motor will emit different tone circularly.

"Beep-beep-" Throttle rage:  
 "Beep-beep-beep-" 15° timing  
 "Beep-beep-beep-beep-" 18.75° timing  
 "Beep--" 22.5° timing  
 "Beep--beep-" 26.25° timing

Move the throttle stick to the bottom position in 3 seconds after hearing corresponding tone, the setting will be completed.



Wait for 2 seconds, motor emits continuously 1 long and 1 short tone. It means the ESC is ready for working.



[ When motor emits tone times ≥5 times, long " Beep--" will represent 5 times]

When ESC drives disc type motor with accelerating throttle, motor may be out-of-step, stalling or requires higher speed, you could try to change timing [ 6S ESC factory default value is 15°, 12S is 22.5°]. Higher timing can accelerate motor speed, but also cause more heat. After changing timing, please test on the ground before flying.

### 05 Protections

|                                 |   |
|---------------------------------|---|
| Start-up Protection             | ESC will cut off output if it fails to start the motor within 3 seconds by accelerating throttle. you need to move the throttle stick back to the bottom position and restart the motor. ( The possible causes: Bad connection or disconnection between ESC & motor, propellers are blocked, etc) |
| Over-load Protection            | ESC will cut off power or output when the load suddenly increases to a very high value, normal operation will resume after moving the throttle stick to the bottom position. ESC will automatically try to restart when ESC and motor are out-of-step.  |
| Throttle Signal Loss Protection | When ESC detects the loss of throttle signal for over 0.32 seconds, it will cut off power or output immediately to avoid an even greater loss caused by the continuous high speed rotation of propellers. ESC will resume the corresponding output after the normal signal is restored.           |

### 06 Trouble shooting

| Trouble                           | Warning Tone  | Possible Cause  | Solution   |
|-----------------------------------|---|---|--|
| ESC was unable to start the motor | "Beep beep beep..."<br>Urgent short tone                    | The throttle stick is not at the bottom position or throttle range is too small.    | Move the throttle stick to the bottom position or reset the throttle range.  |
| ESC was unable to start the motor | "Beep,beep,beep..."<br>Time interval is 1 second            | No output signal from the throttle channel on the receiver.                         | Check if the communication is normal between transmitter and receiver; Check throttle channel connection well.     |
| ESC was unable to start the motor | "Beep-beep,beep-beep-beep,...Beep--beep-"<br>Circular tones | The "Normal/Reverse" direction of the throttle channel on transmitter is incorrect. | Refer to the transmitter instruction and adjust the setting of "Normal/Reverse" direction of the throttle channel. |