

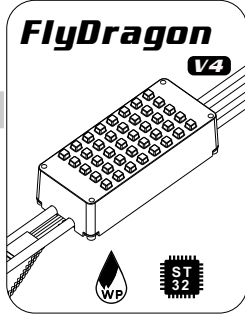

感谢您使用本产品! 本产品功率强大, 错误的使用可能导致人身伤害和设备损坏, 强烈建议您在设备前仔细阅读本说明书并保存, 严格遵守规定的操作程序。我们不承担因使用本产品或擅自对产品进行改造所引起的任何责任, 包括但不限于对附带损失或间接损失的赔偿责任。我们有权在不通知的情况下变更产品的设计、外观、性能及使用要求。

01 主要特性

- FlyDragon V4 电调采用功能强大STM32F051系列MCU, ARM 32位 Cortex内核, 工作频率48MHz;
- 专门针对盘式马达优化的固件, 兼容性非常出色;
- 专门针对多旋翼设计的程序, 使用主动续流ASCF (Active Switch Continued Flow) 技术, 效率更高, 显著降低电调发热;
- 全铝合金外壳, 显著提高散热能力;
- 防溅水, 耐腐蚀, 尤其适合农用植保机的作业使用;
- 固件自适应能力强, 仅保留四种进角设定项, 使用极为简单;
- 最高可支持刷新率高达500Hz的油门信号, 兼容各种飞控 (注: >=500Hz的油门信号皆为非标准油门信号);
- 最高支持14S锂电池, 支持单节锂电池电压4.35V。



02 产品规格

型号	持续电流 (散热良好)	瞬时电流 (10S)	BEC	锂电池节数	重量(供参考)	尺寸(供参考)
FlyDragon V4-80A WP	80A	120A	No	5-14S	215g	86.6x37.8x26mm

03 连线示意图

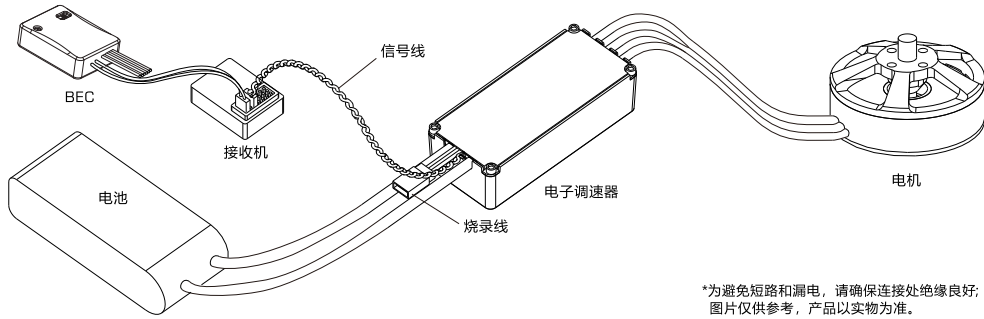

04 尺寸示意图

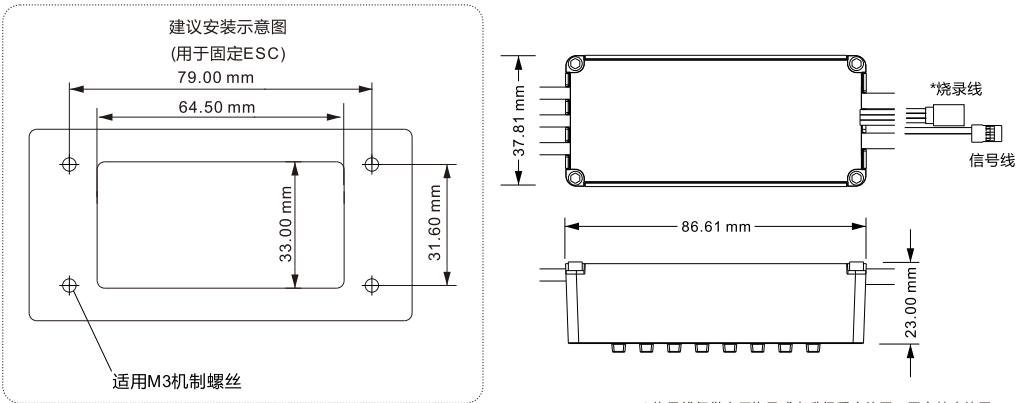

* 烧录线仅供出厂烧录或者升级程序使用, 用户禁止使用

05 编程参数值

1. 正常工作模式



2. 油门行程设定

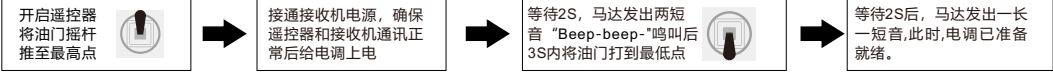

注意: 首次使用无刷电调或更换遥控设备后需要进行油门行程校准。

3. 进角参数设定

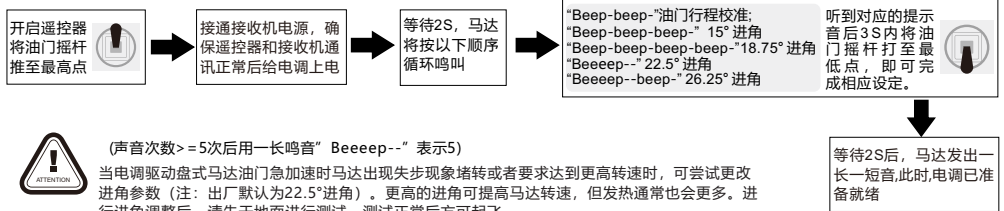

(声音次数>=5次后用一长鸣音“Beeeee-”表示)

当电调驱动盘式马达油门急加速时马达出现失步现象堵转或者要求达到更高转速时, 可尝试更改进角参数 (注: 出厂默认为22.5°进角)。更高的进角可提高马达转速, 但发热通常也会更多。进行进角调整后, 请先于地面进行测试, 测试正常后方可起飞。

06 保护功能

- **启动保护:** 当加大油门时, 三秒内未能正常启动马达, 电调将会关闭动力输出, 油门摇杆需再次置于最低点后可以重新启动马达 (出现这种情况的原因可能有: 电调和马达连线接触不良或有断开、螺旋桨被其他物体阻挡等)。
- **过负荷保护:** 当负载突然变得极大时, 电调会切断动力, 须油门归零后才可正常操作。当马达和电调失步时, 电调会自动尝试重新启动。
- **油门信号丢失保护:** 当电调检测到油门遥控信号丢失0.32秒以上立即关闭输出, 以免因螺旋桨继续高速转动而造成更大的损失。信号恢复后, 电调也随即恢复相应的功率输出。

07 常见故障及提示音

故障现象	警报音	可能原因	解决办法
上电后马达无法启动	“哔哔哔-”的急促短音	油门未归零或行程设置过小	将油门打至最低点或重新设定油门行程
上电后马达无法启动	“哔、哔、哔、.....” (每个间隔1秒)	接收机油门通道无油门信号输出	检查发射机与接收机配合是否正常; 检查油门控制通道接线是否正常
上电后马达无法启动	“哔-哔、哔-哔-..... 哔-哔-” 循环鸣叫	油门通道“正反向”错误	参考遥控器说明书, 调整油门通道正反向设置

08 注意事项

- 电调不可泡水工作。合理的使用电调可延长使用寿命, 电调防溅水, 耐腐蚀。在使用过一定时间后, 请清理电调上的水渍, 污渍, 避免电调短路。
- 电调上的烧录线仅供工厂出厂烧录或升级程序使用, 用户禁止使用此端口。
- 首次使用无刷电调或更换遥控设备后需要进行油门行程校准;
- 当电机出现异常或者要求达到更高转速时, 可尝试更改进角参数;
- 如需更多信息, 请联系飞盈佳乐售后或者技术支持。



Thank you for using our product. Any improper operation may cause personal injury damage to the product and related equipments. This high power system for RC model can be dangerous, we strongly recommend reading the user manual carefully and completely. We will not assume any responsibility for any losses caused by unauthorized modifications to our product. We have the right to change the design, appearance, performance and usage requirements of the product without notice.

01 Main features

- Flydragon V4 ESC use STM32F051 MCU, ARM 32-bit Cortex Core with 48 MHz frequency.
- Optimized firmware is specialized for disc motor, excellent compatibility.
- The firmware is specialized for multi-rotor, uses ASCF technology (Active Switch Continued Flow), higher efficiency, significantly reduce the heat when ESC's working.
- Aluminum cover, significantly improving heat dissipation.
- Splash-proof, corrosion resistant, especially suitable for agricultural plant protection multi-rotor;
- Strong self-adaptable firmware, 4 timing options, very simple to use.
- Supports frequency of throttle signal to 500Hz max, compatible with various kinds of flight control. (≥500Hz throttle signal is nonstandard signal)
- Maximum supports 14S LiPo battery, supports for single LiPo battery voltage up to 4.35V.

FlyDragon V4

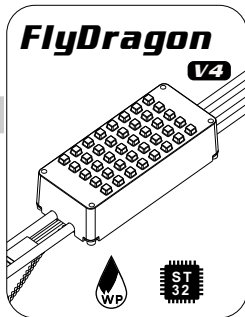

02 Specification

Model	Con. Current (be well-cooled)	Burst Current (10S)	BEC	LiPo cells	Weight (for reference)	Size (for reference)
FlyDragon V4-80A WP	80A	120A	No	5-14S	215g	86.6x37.8x26mm

03 Connection diagram

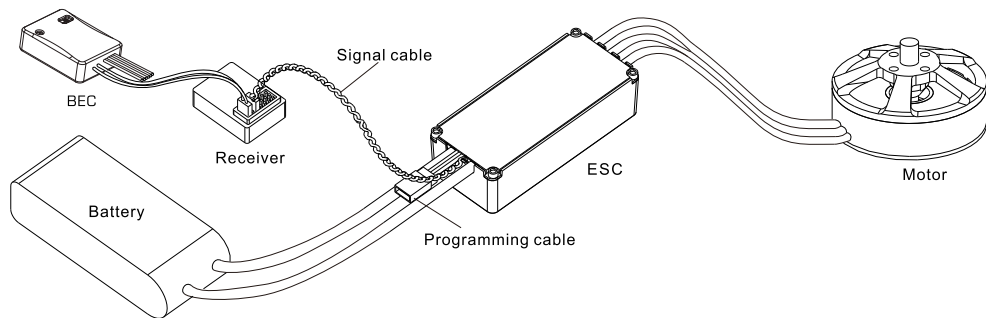

*Please ensure all solder joints are insulated with heat shrink where necessary. All pictures are for reference only.

04 Dimensions

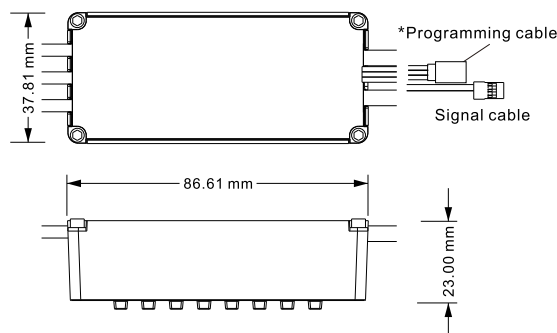
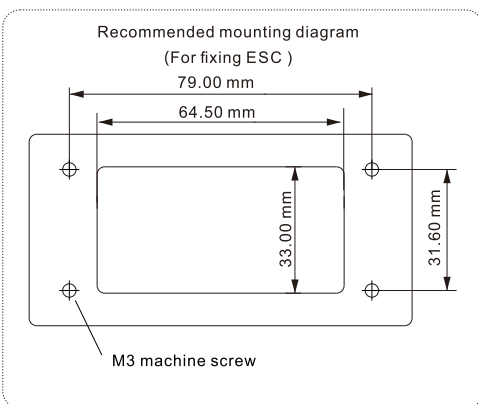

* Programming cable is only for factory download or update firmware, user is not allow to use this cable.

05 Operation instruction

1. Normal start-up

Turn on the transmitter, move the throttle stick to the bottom position



Connect ESC & battery packs, wait for 2 seconds, motor emits continuously 1 long and 1 short tone. It means the ESC is ready for working.

2. Calibrate Throttle Range

Turn on the transmitter, move the throttle stick to the top position.



Connect the receiver to the battery, ensure the communication is normal between the transmitter and receiver, then power on the ESC.

Wait for 2 second, after motor emits 2 short "BEEP-BEEP", move the throttle stick to the bottom position in 3 seconds.



Wait for 2 seconds, motor emits continuously 1 long and 1 short tone. It means the ESC is ready for working.

Attention: Please calibrate throttle range when first time to use ESC or change transmitter.

3. Set Timing

Turn on the transmitter, move the throttle stick to the top position.



Connect the receiver to the battery, ensure the communication is normal between the transmitter and receiver, then power on the ESC.

The motor will emit different tone circularly.

"Beep-beep-" Throttle rage;
 "Beep-beep-beep-" 15° timing
 "Beep-beep-beep-beep-" 18.75° timing
 "Beeeeeep-" 22.5° timing
 "Beeeeeep-beep-" 26.25° timing

Move the throttle stick to the bottom position in 3 seconds after hearing corresponding tone, the setting will be completed.



(When motor emits tone times ≥5 times, long "Beep--" will represent 5 times)
 When ESC drives disc type motor with accelerating throttle, motor may be out-of-step, stalling or requires higher speed, you could try to change timing (ESC factory default value is 22.5°). Higher timing can accelerate motor speed, but also cause more heat. After changing timing, please test on the ground before flying.

Wait for 2 seconds, motor emits continuously 1 long and 1 short tone. It means the ESC is ready for working.

06 Protections

- **Start-up Protection:** ESC will cut off output if it fails to start the motor within 3 seconds by accelerating throttle. you need to move the throttle stick back to the bottom position and restart the motor. (The possible causes: Bad connection or disconnection between ESC & motor, propellers are blocked, etc)
- **Over-load Protection:** ESC will cut off power or output when the load suddenly increases to a very high value, normal operation will resume after moving the throttle stick to the bottom position. ESC will automatically try to restart when ESC and motor are out-of-step.
- **Throttle Signal Loss Protection:** When ESC detects the loss of throttle signal for over 0.32 seconds, it will cut off power or output immediately to avoid an even greater loss caused by the continuous high speed rotation of propellers. ESC will resume the corresponding output after the normal signal is restored.

07 Trouble shooting

Trouble	Warning Tone	Possible Cause	Solution
ESC was unable to start the motor	"Beep beep beep..." Urgent short tone	The throttle stick is not at the bottom position or throttle range is too small.	Move the throttle stick to the bottom position or reset the throttle range.
ESC was unable to start the motor	"Beep,beep,beep..." Time interval is 1 second	No output signal from the throttle channel on the receiver.	Check if the communication is normal between transmitter and receiver; Check throttle channel connection well.
ESC was unable to start the motor	"Beep-beep,beep-beep-beep,..." Beep--beep-" Circular tones	The "Normal/Reverse" direction of the throttle channel on transmitter is incorrect.	Refer to the transmitter instruction and adjust the setting of "Normal/Reverse" direction of the throttle channel.

08 Attention

- ESC can not work under water. Reasonable use of ESC can prolong the service life. Splash-proof and corrosion resistant, please clean up the water and stains on the ESC after a certain period of time, to avoid electric short circuit.
- The programming cable is only for the factory download firmware, user is prohibited from using this cable.
- User need to calibrate the throttle range when starting to use a new ESC or change another transmitter.
- When some abnormality occurs in ESC driving the motor or need the motor to reach a higher RPM, user can try to change the timing.
- Please contact Flycolor sales or technical support for more information.